

| REVISION HISTORY |             |      |          |
|------------------|-------------|------|----------|
| REV              | DESCRIPTION | DATE | APPROVED |
|                  |             |      |          |

Copyright 1/12/2010  
www.PhilScott.Net all rights reserved

# COMBINATION CONDENSING BOILER #2 CONTROLS

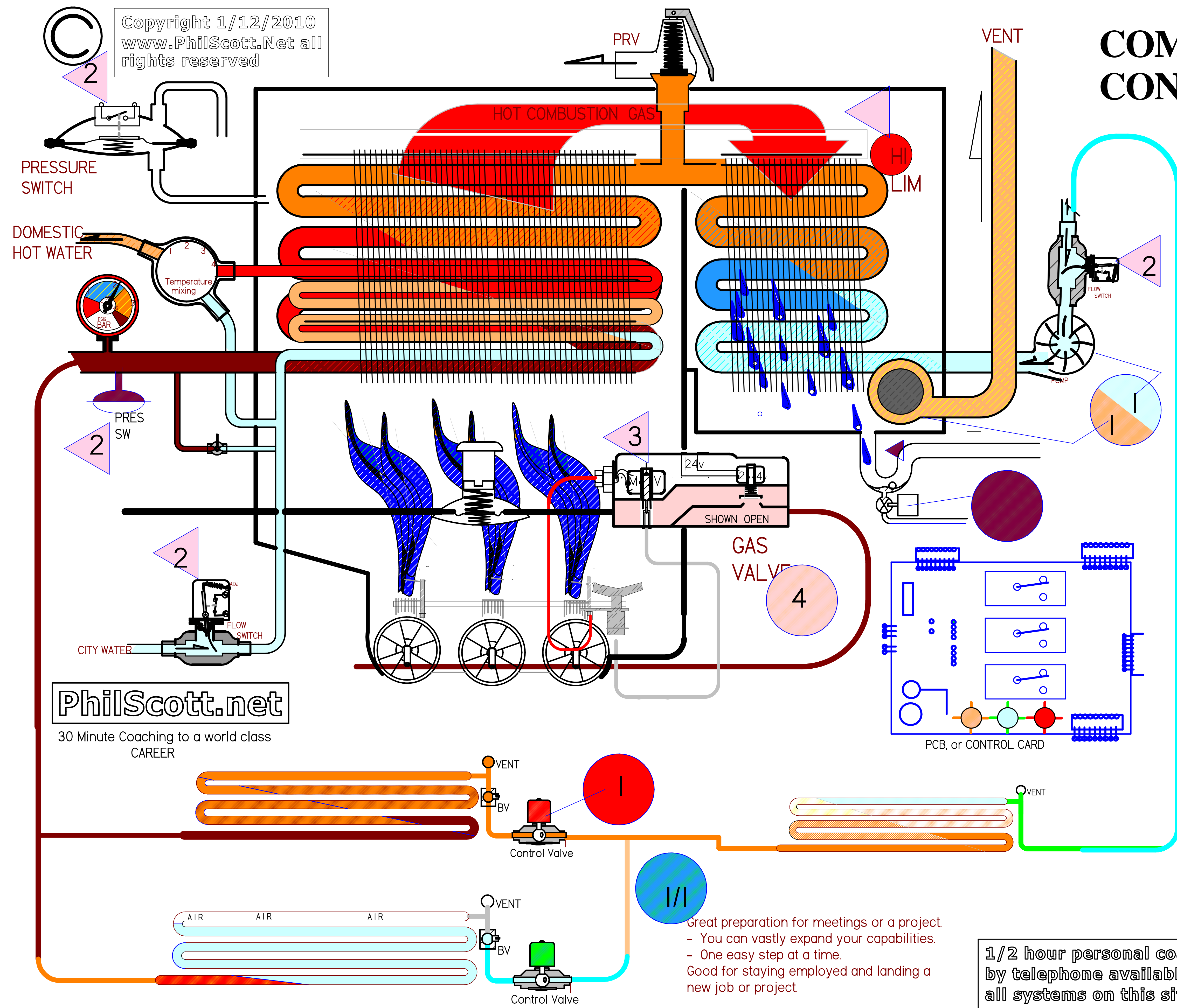

- SUMMARY SEQ/ of EVENTS
- 1 Room stat calls for heat.
  - 2 Starts exh fan and pump, #1
  - 3 Safety switches close. #2,
  - 4 Pilot gas flow/ Ignition.
  - 5 Flame sensed by PCB opens gas valve on time delay #4
  - 6 Condensate drain fails. kills #4

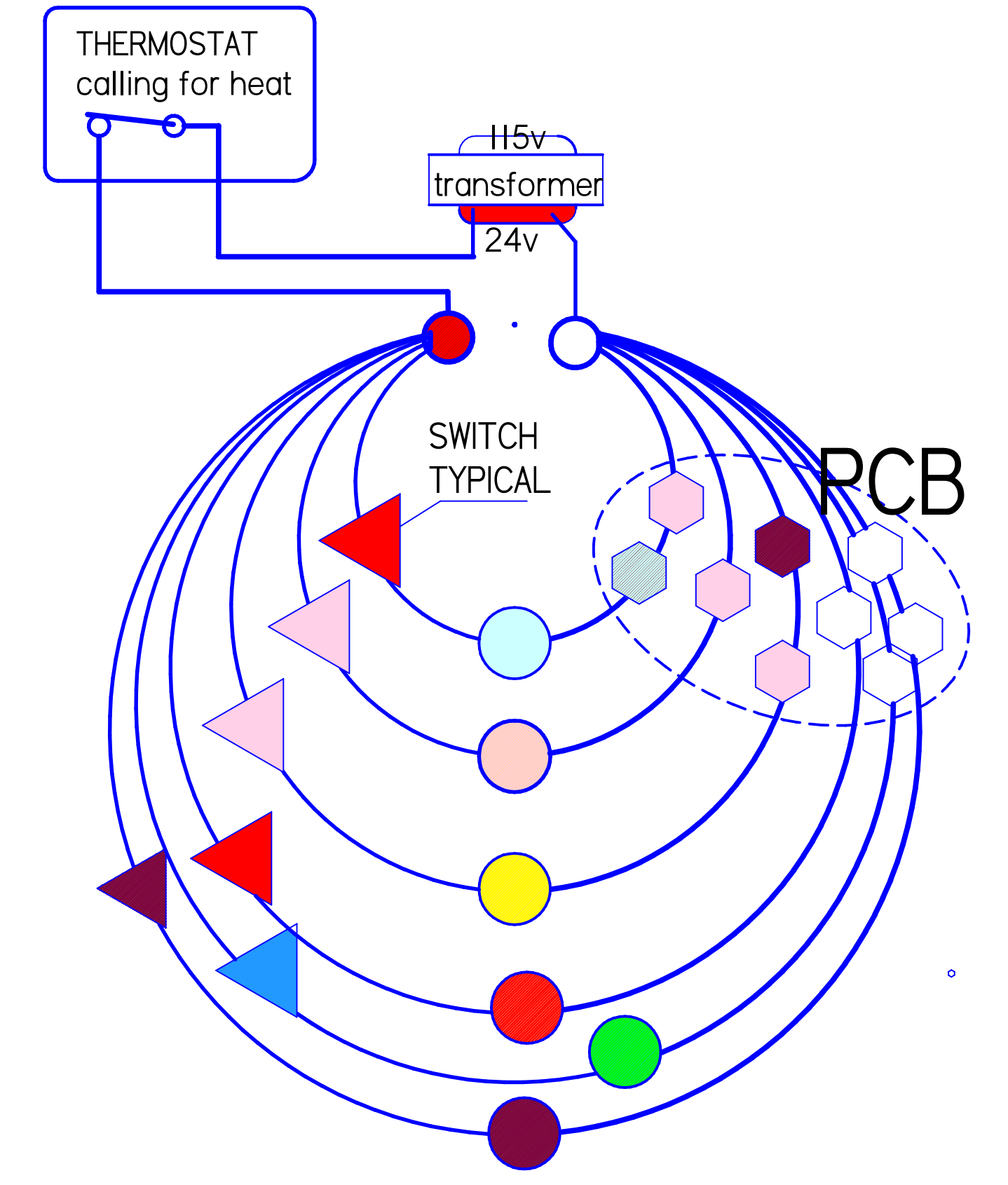
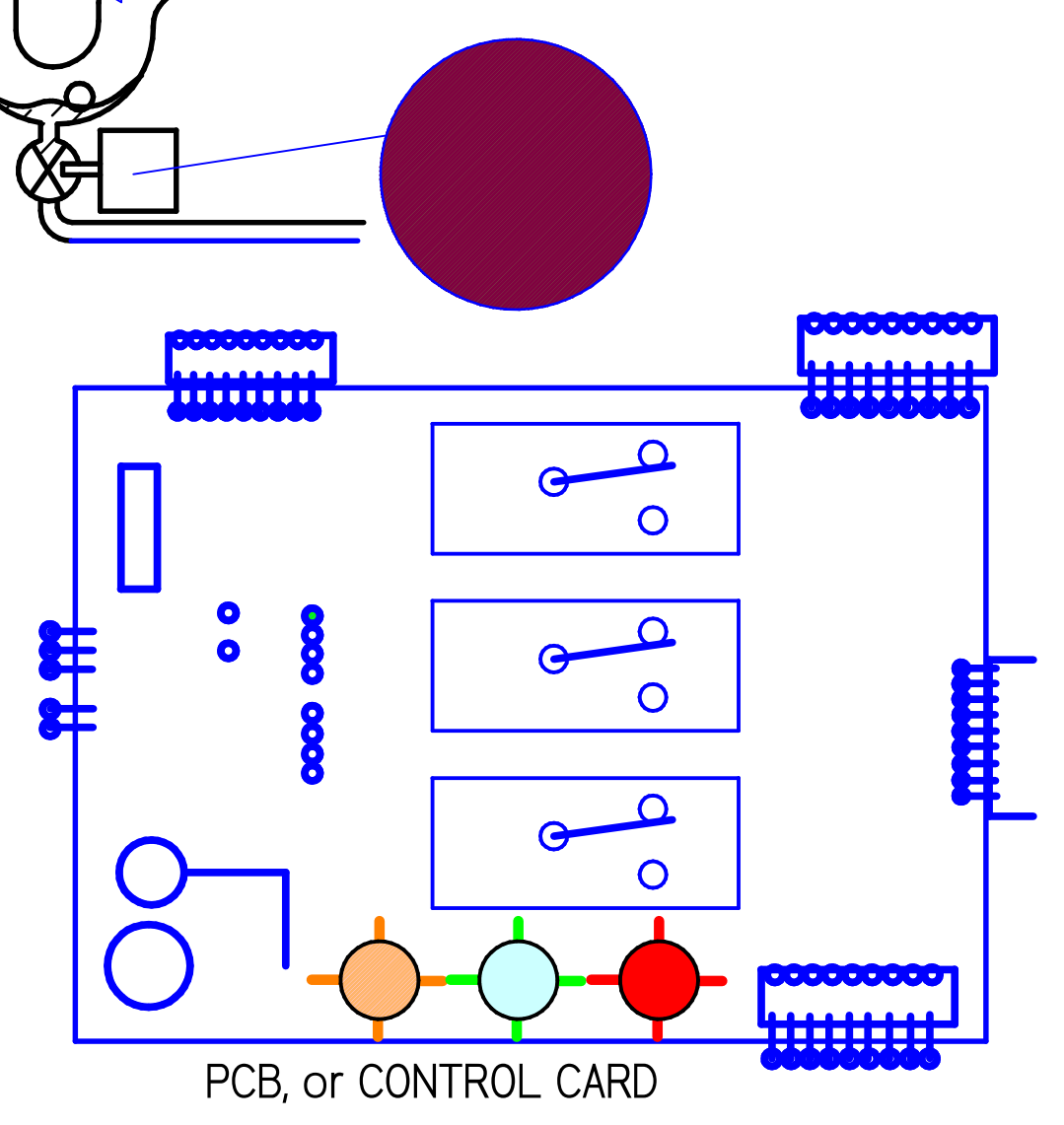

**PhilScott.net**  
30 Minute Coaching to a world class CAREER

Great preparation for meetings or a project  
- You can vastly expand your capabilities.  
- One easy step at a time.  
Good for staying employed and landing a new job or project.

1/2 hour personal coaching by telephone available for all systems on this site.

**COMBINATION CONDENSING BOILER**  
2 of 8